

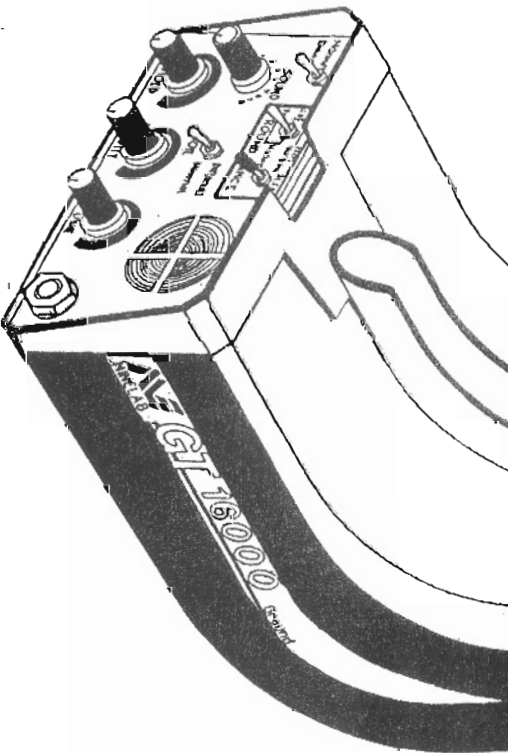

GT 16000

Ground Tracker

INSTRUCTION MANUAL



MINELAB ELECTRONIC INDUSTRIES LTD.,

36 George Street, Stepney, South Australia 5069.

Postal Address: P. O. Box 35, Stepney, South Australia 5069.

Telephone: (08) 363 0899

TELEX: AA87448 FAX: (08) 363 0973

GT16000 Ground Tracker Instruction Manual

Version 1.0

November, 1987

- ii -

TABLE OF CONTENTS

1.	GENERAL DESCRIPTION	1
2.	BASIC OPERATION	2
2.1	Assembly Procedure	2
2.2	Start-up Procedure in Basic Search Mode	4
2.3	Telephone Socket	5
2.4	Batteries	5
2.5	Search Coil	7
3.	EXPLANATION OF CONTROLS	7
3.1	VOLUME Knob and On/Off	7
3.2	SOIL Switch	7
3.3	SENSITIVITY Knob	8
3.4	SOUND Switch	8
3.5	THRESHOLD Knob	8
3.6	DISCRIMINATE Knob	9
4.	GROUND NOISE REJECTION	10
4.1	Automatic Ground Balancing (AGB)	10
4.2	Automatic Ground Balance Tracking (AGB Tracking)	11
4.3	Searching Modes	12
5.	DETECTION TIPS	13
5.1	General	13
5.2	Pinpointing an Object	14
5.3	Recommended Technique	15
5.4	Ground Noises	16
5.5	Clay Domes	17
5.6	Searching for Gold	18
6.	PROPER CARE OF YOUR DETECTOR	19
7.	WARRANTY AND SERVICE	19
8.	SPECIFICATIONS	20

1. GENERAL DESCRIPTION

The GT16000 Ground Tracker represents a new era in high performance metal detectors. MINELAB engineers, building on the superior technology of the GS15000, have now developed a detector which features genuine automatic ground balancing without any loss of sensitivity.

In the past, it has been well known that high performance detectors must have a manual ground balancing control. Many of the so-called "automatic detectors" essentially operated with a fixed ground balance setting and reduced sensitivity, giving the appearance of good ground noise elimination but poor depth penetration as a consequence. It is well known that this type of detector fails to operate satisfactorily in highly mineralized ground. By using the computing power of a microprocessor, the GT16000 carries out the ground balancing procedure using exactly the same operation as a user does when carrying out manual ground balancing.

The only difference is that it carries it out more precisely and more rapidly than using manual operation. Furthermore, it does it continuously as the detector head is swept over the ground. Unlike even the most dedicated detector operator, it never tires of ground balancing.

Automatic Ground Tracking allows the operator to COVER MORE GROUND IN LESS TIME.

Inexperienced detector users often cannot take advantage of manual ground balancing controls because they are not skilled in this procedure. With the GT16000 Ground Tracker, the novice venturing into the field for the first time will be using a detector which automatically adjusts the ground balance setting with an accuracy equal to the most experienced operator. This, together with the ability to reject ironstone interference, places in the hand of the amateur the technical ability to seek nuggets, coins or treasure with the skill of a professional.

Other features of the GT16000 include high sensitivity, superior capability to reject ground noise in highly mineralized soils, rugged construction, and a variable discriminator which adjusts its discriminating power to achieve maximum capability under all soil conditions. Selectable special audio output modes include a built-in signal booster as well as a unique "enhancer" mode designed to identify small and medium sized objects in highly variable ground. The detector can be readily converted to either shaft mount or hip mount mode of operation.

The GT 16000 is a unique instrument which places the skills of the professional in the hands of the amateur, while at the same time allowing the professional to cover more ground more accurately and more rapidly than was previously possible.

2. BASIC OPERATION

2.1 Assembly Procedure

- 1 Unpack the detector and check that the following parts are included: Instruction Manual, Warranty Card, Control Box, Main Shaft, Arm-rest, Search Coil and Cable, Lower Shaft, Bag, Extension Cable, Skid Plate. Keep the packing carton in case you need to repack the unit at any time in the future.
- 2 Fill in the Warranty card and mail it.

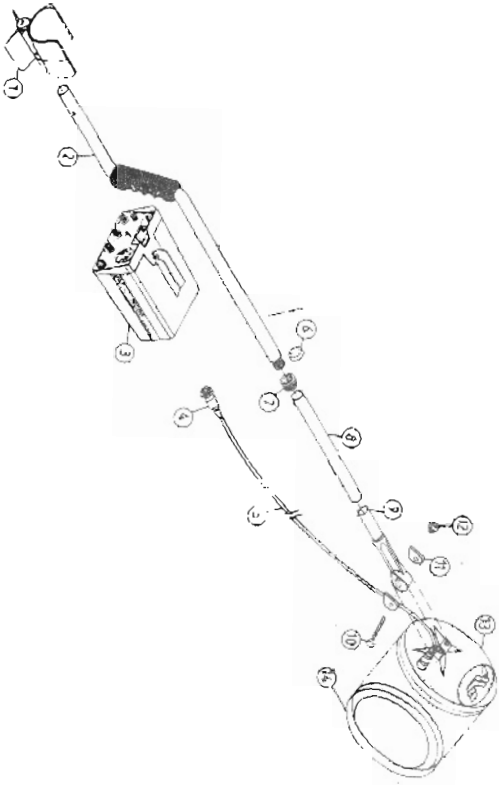

Figure 1. GT16000 Assembly Diagram

- 2 -

3. Slide the Lower Shaft (8) containing the Search Coil and Cable into the Main Shaft (2) to a convenient length and make sure it "clicks" into place. Tighten the locking nut (7) by hand to make the connection firm.
 4. Slide the Arm-rest (1) (with support fins towards the rear) over the back of the Main Shaft (2) so that it "clicks" firmly at a convenient position. You can tighten or loosen it about the forearm by bending the fins. (You can buy an optional Velcro strap to provide extra firmness during operation.)
 5. Attach the Control Box (3) to the Main Shaft (2) at a distance from the handle grip convenient for you to operate the RESET switch. Ensure that the surfaces at the connection are free from grit. (Do not twist the control box when removing it - grip it firmly and pull it straight off in line with the shaft.)
 6. Wind the Cable (5) from the Search Coil (13) around the shaft fairly tightly (but without strain) and connect and screw the Cable plug (14) to the socket on the Control Box (3). Experienced operators recommend that you use heavy-duty insulating tape to secure the Cable to the Shaft to prevent unnecessary movement and snagging on objects.
 7. Attach the Skid Plate (14) to the Search Coil to prevent abrasion and wear. It will "click" firmly into place.
 8. Install the batteries (see Section 2.4 below) and you are ready to start searching.
 9. You should use high quality headphones for serious searching. The loudspeaker is less sensitive and without headphones your ears are not protected from stray noises.
 10. **Hipmounting or Strapping** is easily achieved by putting the control box into its protective Bag, which can be threaded onto your belt, or suspended from a strap. Experienced users have found strapping most convenient if they spend a lot of time putting down and picking up the detector while working.
- Attach the Extension Cable between the Cable Plug and the Control Box and fix the connector firmly to the shaft using tape. After extensive use, the moving cable will deteriorate in its electronic properties and add unwanted noise to the system. We recommend that you replace the extension cable when noise becomes excessive.

The Battery Replacement Procedure is as follows:

- 1 Turn the detector off.
- 2 The battery compartment is located at the bottom of the Control Box. To remove the battery lid, press down on the end of lid nearest the front panel and slide it out.
- 3 Take out the two battery packs, taking care not to damage the connecting wires.
- 4 Remove the batteries from the packs and replace them with new ones. Be certain to replace them in their correct positions. Diagrams displaying polarity are on the packs. **Incorrect polarity will damage the detector.**
- 5 Carefully replace the loaded battery packs and slide the lid shut until it "clicks" firmly into place.

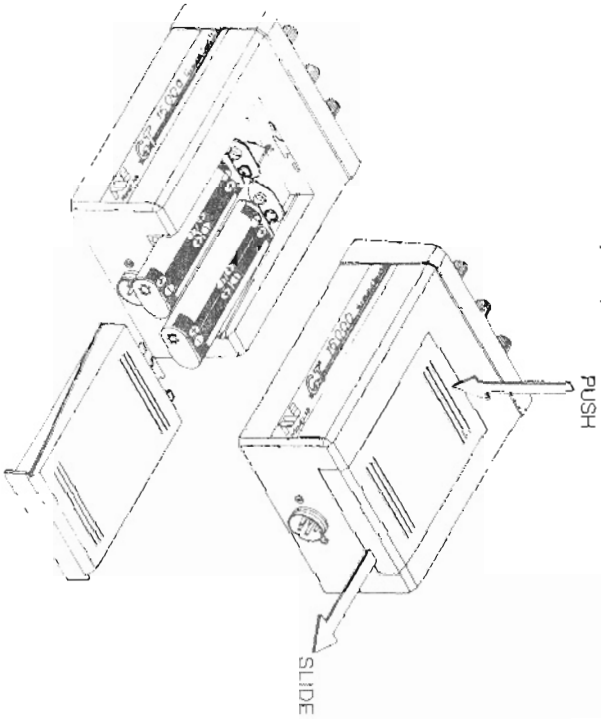

Figure 3. Battery removal and installation.

2.5 Search Coil

The GT 1600G will only operate with Search Coils manufactured by Minefield Electronic Industries. The coil configuration is a double-D shape. Its advantages are greater depth, a wider search width, excellent performance in difficult soils and ease of pinpointing.

The standard eight inch coil (SUPERSEARCH 8) supplied with the unit is suitable for most searching. The eleven inch coil will find larger targets deeper and cover a wider area on each sweep of the Search Coil. However it is not as effective for smaller targets.

Use a skid plate to protect the Search Coil housing from abrasion and wear.

3. EXPLANATION OF CONTROLS

3.1 VOLUME Knob and On/Off



The detector is "on" when the knob is turned completely anticlockwise. On turning the knob, you should feel a slight resistance and hear a click: this signifies that the machine is in the "On" position. When used in the field with high quality headphones, the operator will achieve the best results with the knob set between half and the maximum setting.

3.2 SOIL Switch

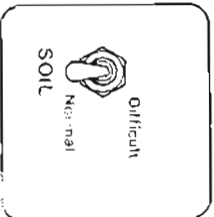

This toggle switch should always be set on the "Normal" position for good or clear ground. The "Difficult" setting slightly reduces sensitivity and should be selected only for ground highly concentrated in ironstone or mineralization. If the ground still produces large variable responses, then you should decrease the sensitivity by turning the sensitivity knob anticlockwise. By doing so, some "depth" will be lost.

The detector will give a high pitch "chirp" if it overloads. This will occur when you sweep the Sensing Head close to a large object or if the head is brought too close to very "hot" ground. If you cannot bring the head close to the "hot" ground, set the Soil Switch to "Difficult".

